



## SX Performance™ Model 18207 In-Line Electric Fuel Pump Performance Specifications and Installation Instructions

Outlet pressure/flow	120 GPH @ 45 psi, 12 VDC
Maximum pressure	90 psi
Current Draw	15 amps @ 45 psi
Inlet/Outlet Port Size	AN-12 (O-Ring Seal)
Conversions:	1 gal. gasoline weighs 5.75 lbs avg. at 70°F 1 bar = 14.5 psi

Note: This Pump is not intended for street use and is not legal for sale or use on emission controlled motor vehicles.

### **CAUTION!**

Installation of this product should only be performed by those persons thoroughly knowledgeable in the repair and modification of high performance automotive fuel systems.

### **WARNING: Fuel system may be under pressure!**

Do not loosen fuel system connections until relieving pressure. Fuel may leak when loosening fuel system connections. Eliminate potential fire hazards before loosening any fuel system connections. Always wear appropriate personal safety equipment such as safety goggles and other apparel as needed, for protection from debris and sprayed gasoline. Work in a well-ventilated area and keep an approved fire extinguisher nearby. Extinguish any open flames and eliminate all sources of ignition in the area of the vehicle before proceeding with the installation.

Installation Guidelines: To ensure proper performance of this pump, the following installation guidelines must be strictly adhered.

- The pump must be rigidly mounted, below the fuel tank (or at the very least below the fuel line) and as close to the tank as possible. If you are using a stock fuel tank, installation of a reservoir style sump in the bottom-rear of your fuel tank is required. Follow all manufacturers' recommendations when installing a reservoir style sump.
- A by-pass style fuel pressure regulator must be used with this pump to allow proper heat dissipation. AN-8 (1/2") minimum return line size is recommended.
- Utilize AN-12 line size (3/4"), fittings and connections minimum from the tank to the pump inlet. Minimize restriction on the inlet side of pump. The pump must have a generous supply (3.0 gpm minimum) of gravity fed fuel at the inlet to avoid damage caused by pump cavitation.
- Use a high flow capacity fuel filter (60-100 micron) installed between the fuel tank and pump inlet.
- Use at least 10 gage wire for power supply to the pump to prevent the wire from overheating and creating a fire hazard and to minimize voltage drop across wires.

Typical Installation Instructions:

1. With the ignition off and engine cool, disconnect the negative battery terminal and relieve the fuel system pressure. **See the above warning for proper precautions.**
2. Disconnect the existing pump fuel lines. Plug the open fuel line ends to prevent leakage and foreign matter from entering the fuel system. Remove the pump mounting screws and remove the existing pump.
3. Mount the new pump in a suitable place on the vehicle chassis using quality 1/4" hardware (not supplied). Refer to Figure 1 for mounting hole locations. The pump must be mounted on a horizontal level that is even with or below the bottom of the fuel tank and as close to the fuel tank as possible. Ensure all fuel lines from the pump to the carburetor or fuel injection rails are high-pressure grade (200 psi minimum). Replace existing fuel lines as necessary so they line up with the new pump.

Fuel lines from pump outlet to fuel rails should be AN-10 minimum. AN-12 is recommended.

**CAUTION: Use common sense when routing fuel lines and electrical harnesses. Keep them away from hot exhaust components and/or moving parts. Properly secure lines to prevent chaffing or abrasion. Fuel lines should never be routed inside the passenger compartment of the vehicle! It is also recommended that all fuel lines be routed on the outside of chassis frame rails wherever possible.**

7. Connect and tighten fittings to the inlet and outlet fuel lines, see Figure 1.
8. Connect electrical power (12 VDC) to the pump at the appropriate terminals using spade or eyelet type connectors and 10 gage wire (minimum). Double check polarity. **CAUTION:** The pump must be connected to the vehicle electrical system so that the pump is on only when the ignition key is in the "on" or "start" position and must have a 30 amp (maximum) in-line electrical fuse. The pump must not be connected directly to the battery. Ensure that the pump negative terminal is electrically grounded properly to the vehicle chassis.

**CAUTION: Use care to route all electrical wires clear of moving suspension, driveline or exhaust components. Protect wires from abrasion and road obstructions.**

9. If not previously equipped, attach a fuel pressure gauge to the fuel system fuel rail or fuel pressure regulator.
10. Reconnect the battery. Turn the ignition to ON without starting the engine and check for fuel pressure after allowing the pump to run for several seconds. If there is no pressure, turn the ignition to OFF. If no pressure is registered on the gauge after running the pump for several seconds and you have found no leaks, verify adequate fuel supply at the pump inlet and check all fuel and electrical connections to determine the cause.

### **WARNING!**

If any leaks exist, immediately shut the engine off and repair before continuing.

11. Once steady fuel pressure is obtained, start the engine and check the fuel system for leaks. Set desired final pressure at the fuel regulator and lock the adjuster in place.

Congratulations, your vehicle can now take full advantage of the exceptional performance capabilities of your new SX Performance™ product!

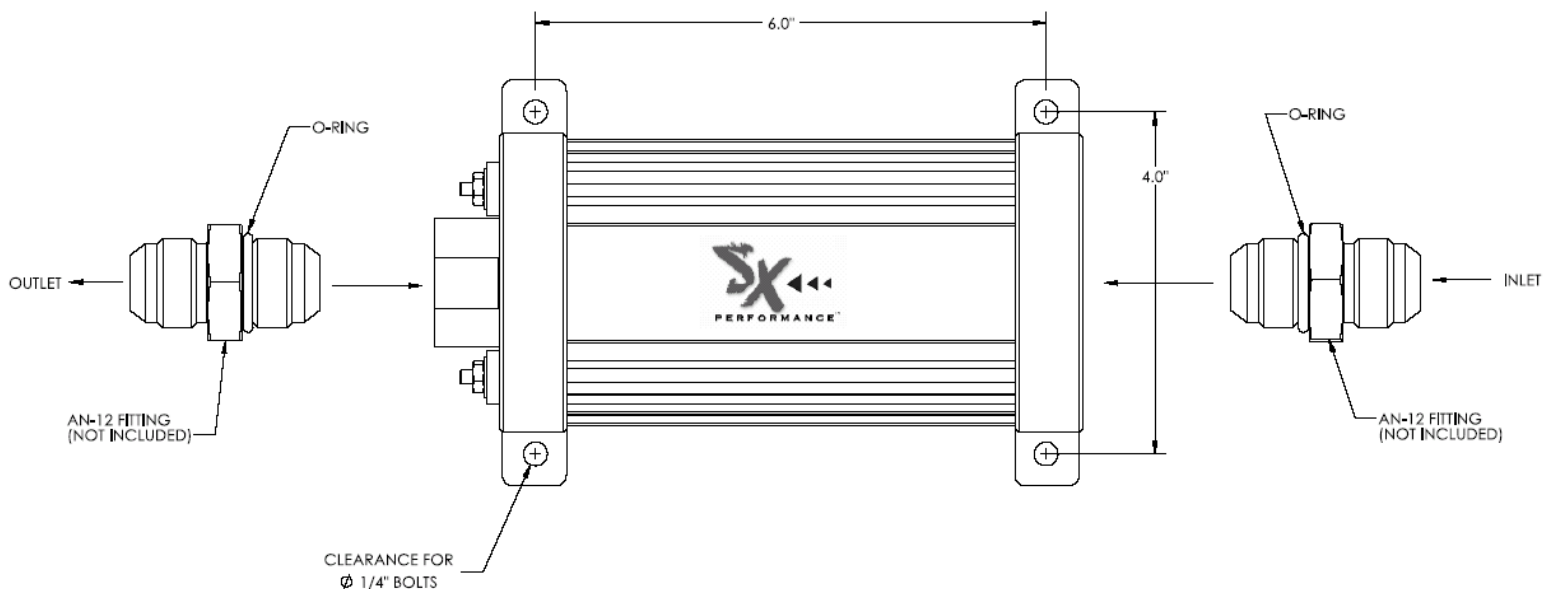

Figure 1 – SX Performance™ Model 18207 Fuel Pump

This document was created with Win2PDF available at <http://www.daneprairie.com>.  
The unregistered version of Win2PDF is for evaluation or non-commercial use only.